

INDOOR UNIT

RSUB-58-L

CODE OPTIONS

CSD-1 Manual Reset LWCO

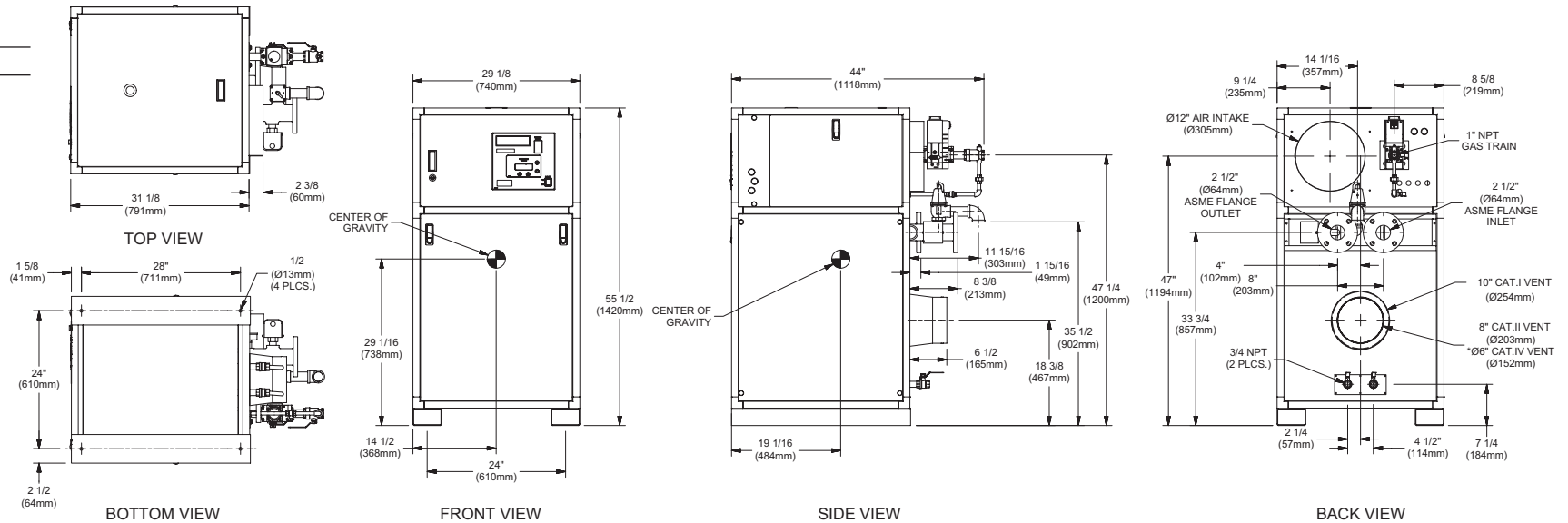

Notes:

1. Dimensions are approximate and should not be used to "rough-in" equipment.
2. Dimensions are subject to change without notice.

BOILER CERTIFIED RATINGS & CAPACITIES

Fuel Type	Natural/Propane Gas	Boiler FLA	11.3*
Input BTU/hr.	1,250,000 / 366 kW	Min. Gas Pressure Required	2" W.C.**
Output BTU/hr.	1,066,250 / 312 kW	Max. Gas Pressure Allowed	14" W.C.
Electrical Requirements	(L1, NEU, GND) 120VAC/1 ph/60 hz	Operating Weight	748 lbs. / 340 kg.

BOILER TEMPERATURE RISE / PRESSURE DROP

20°F / 11.1°C				25°F / 13.9°C				30°F / 16.7°C				35°F / 19.4°C			
Flow Rate		Pressure Drop		Flow Rate		Pressure Drop		Flow Rate		Pressure Drop		Flow Rate		Pressure Drop	
GPM	L/s	Ft	kPa	GPM	L/s	Ft	kPa	GPM	L/s	Ft	kPa	GPM	L/s	Ft	kPa
107.0	6.8	2.14	6.3	85.6	5.4	1.42	4.2	71.3	4.5	1.01	3.0	61.1	3.9	.76	2.2

BOILER / WATER HEATER TRIM & CONTROLS

Main Gas Valve	Dungs MBC-SE	Air Switch	Cleveland NS2
Firing Valve	1"	Blower Motor	Fasco 1 hp - FLA 2.1
Ignition Control	Honeywell RM7895C	Relief Valve - MW	3/4" x 3/4" set @ 125 psi
Operating Control	HeatNet®	Relief Valve - MB	3/4" x 1" set @ 50 psi
High Limit	Jumo	Flow Switch	TACO
Main Ball Valve	1"	Pilot Regulator	White-Rodgers 25M

A.S.M.E.

ASME Sect IV Htg Surface	133.76 Sq. Ft. / 12.43 Sq. M.	Design Data	Max. 160 psig & 250°F
Water Volume	4.7 gal / 17.79 Liters		

* Add circulator amps.

** For incoming gas pressures lower than 2" W.C. natural or propane, consult factory.

WATER HEATER HOURLY RECOVERY CAPACITY (GPH & LPH)

40°F	22°C	60°F	33°C	80°F	44°C	100°F	56°C	120°F	67°C	140°F	78°C
3102	11727	2068	7818	1551	5864	1241	4691	1034	3909	886	3351

Futera III 1250 model water heater not available for sale in Canada due to NRCAN Regulations.

REP FIRM _____
 SUBMITTED BY _____
 JOB NAME _____
 ARCHITECT _____
 ENGINEER _____
 CONTRACTOR _____
 DATE _____

FUTERA III 1250

Category I, II or IV Appliance

(see Installation and Operation Manual for venting information)



A Division of Mestek, Inc.
 Westfield, MA 01085
 (413) 568-9571

OUTDOOR UNIT

RSUB-113-B

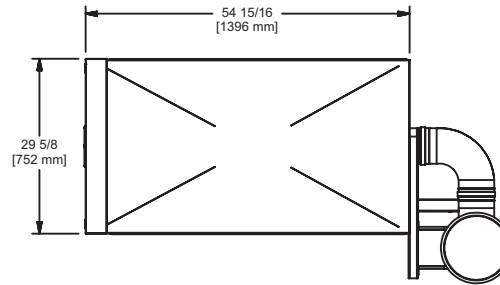

TOP VIEW

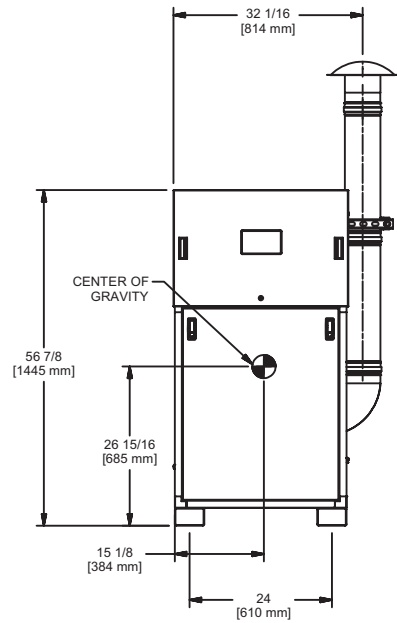

FRONT VIEW

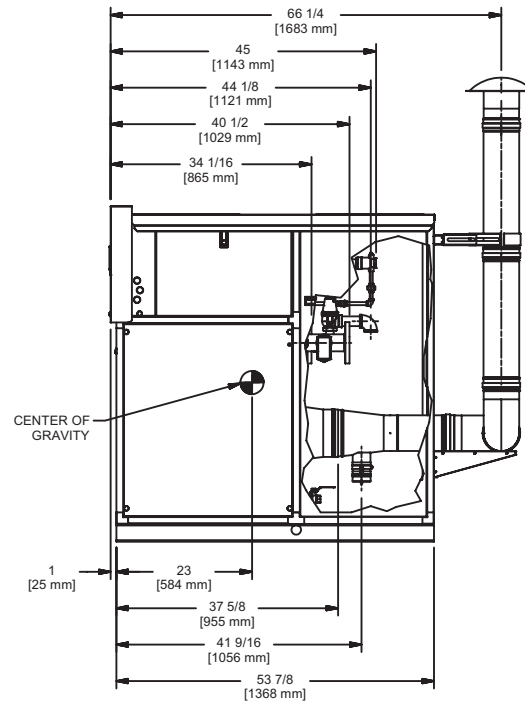

SIDE VIEW

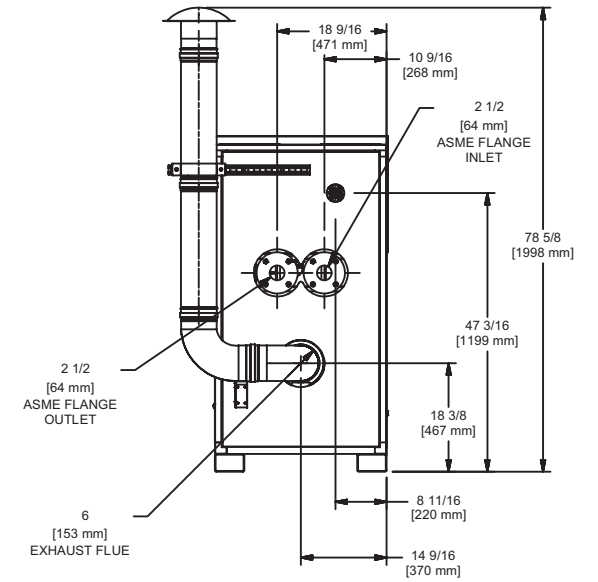

BACK VIEW

FUTERA III 1250

Notes:

1. Dimensions are approximate and should not be used to "rough-in" equipment.
2. Dimensions are subject to change without notice.